

**REGULATIONS ON  
ALLOWABLE DIMENSIONS AND WEIGHT OF  
CARGO AND PASSENGER VEHICLES  
ALONG ROADS NETWORK OF  
THE ISLAMIC REPUBLIC OF IRAN**

**Article 1: The words and terms used in this regulation shall have the following meanings:**

- a. Vehicle:** Motorized as well as non-motorized means of transportation, used to carry passengers and goods along the roads.
- b. Self-Propelling (Motor Vehicle):** Any type of motorized vehicle capable of moving along the roads, except the railway vehicles.
- c. Truck:** Motorized cargo vehicle, which the cargo carrying part connected to the chassis, to be the capacity of more than 6 tons.
- d. Tractor-Truck:** Motorized cargo vehicle that pulls a trailer or a semi-trailer.
- e. Heavy Duty Motor Vehicle:** Any type of vehicle and related instruments capable of carrying oversized heavy cargo with gross weight of over 40 MT.
- f. Articulated Vehicle:** Vehicle consisting of a Tractor- truck or a motorized vehicle and a trailer or a semi-trailer connected to.
- g. Truck Tractor Semi-Trailer:** Articulated vehicle including a tractor and a semi-trailer connected to.
- h. Bus:** Passenger vehicle, maximum capacity of which is determined based on the standards related to the minimum space allocated to each passenger.
- i. Axle:** means a structure that is wholly in the same or approximately the same transverse plane and that is supported by wheels on which or with which it revolves;
- j. Axle Group:** means any 2 or more successive axles on a vehicle or combination of vehicles;
- k. Axle Load:** The load or weight imposed by each axle of the vehicle on the road surface.

- l. Vehicle Capacity:** Maximum allowable weight of cargo or number of passenger determined by the manufacturer, approved by the Ministry of Industry, Mine and Trade and indicated in the Vehicle Registration Plate.,
- m. Dead or Empty Weight (Cargo Excluding):** Weight of the vehicle without driver, passengers, and cargo; but with filled fuel tank and other tools that are normally carried by the vehicle.
- n. Gross Vehicle Weight (GVW):** means the number of kilograms derived by adding the weights on all the axles of a vehicle.,
- o. Gross Combination Weight (GCW):** Maximum traction or combination weight that can be carried by a cargo vehicle (Gross Vehicle Weight + Gross Trailer or semitrailer Weight)
- p. Trailer:** Vehicle pulled by a motorized vehicle.
- q. Semi-Trailer:** a vehicle without motive power designed to be drawn by a motor vehicle or truck tractor and so constructed that an appreciable part of its weight and that of its load rests on and is carried by the motor vehicle or truck tractor.,
- r. Vehicle Code:** The reference code of vehicles classification. The first two digits indicates type of the vehicle and number of the axles (4 bus, 5 truck, 6 tractor-truck), the second two digits represents type of the articulated vehicle and number of the axles of trailer or semi-trailer connected to it (7 trailer, 8 semi-trailer), and the last two digits illustrates the total number of wheels.

**Example:** Code number 537422 is related to a three-axle truck with a four-axle trailer and 22 wheels; 5 indicates the truck, 3 indicates the number of truck axles, 7 represents the trailer, 4 represents number of the trailer axles, and 22 illustrates total number of the wheels.

**s. Latin Letters Associated with the Vehicle Code in Tables:**

**R** shows the necessity of using radial tires with minimum weight of 36.5 cm for the two-wheel axles.

**S** shows that the vehicle has two axles in the lead group.

**W** shows that the rear axles of trailer include a two-wheel axle.

**L** shows that the distance between two adjacent axles of the trailer exceeds two meters.

Letters **A**, **B**, **C** and **D** represent various axle groups of the vehicles.

## Article 2: Allowable Dimensions of Vehicles on the National Roads Network

A. **Length** : Means the greatest overall longitudinal dimension of a vehicle or combination of vehicles including load is indicated in Table 1.

**Table 1: Allowable Length of Various Types of Cargo and Passenger Vehicles on National Roads Network**

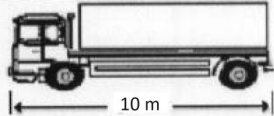
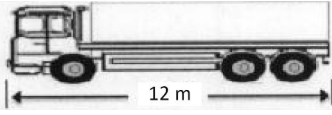
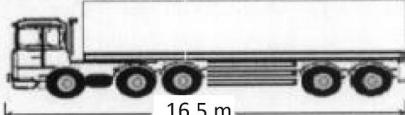
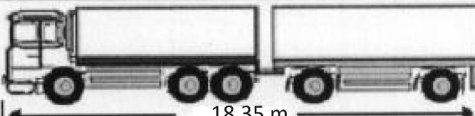
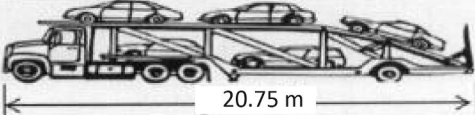
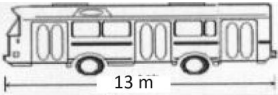
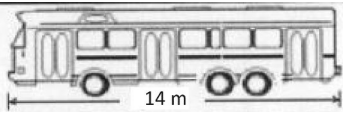
No.	Vehicle	Maximum Allowable Length of Vehicle Including Load (m)	Image
1	Two-Axle Truck	10	
2	Three -Axle Truck	12	
3	Various Truck – Tractor semi-trailer	16.5	
4	Truck with Trailer	18.35	
5	Car carrier (Truck +Trailer)	20.75	
6	Two-Axle Bus	13	
7	Three(+)-Axle Bus	14	

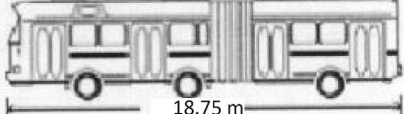
8	Trolley Bus	18.75	
---	-------------	-------	--

**Remark:** Maximum length indicated in the table is the largest length from the front end to the rear end of the vehicle or the cargo.

**Note:** Maximum front cargo overhang from center of the first axle is 1.50 m and maximum rear cargo overhang from center of the last axle is 3 m for trucks and 5 m for trailers. Cargos with larger overhangs are not allowed to move along the national roads network under any conditions.

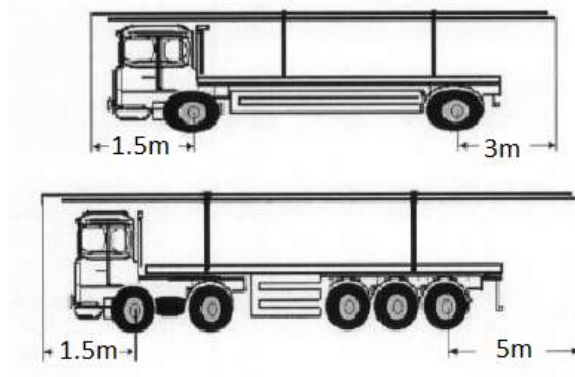

### B. Width

Maximum allowable width of all cargo vehicles with cargo and all passenger vehicles is 2.6m, exclusive of the side mirrors and lights.

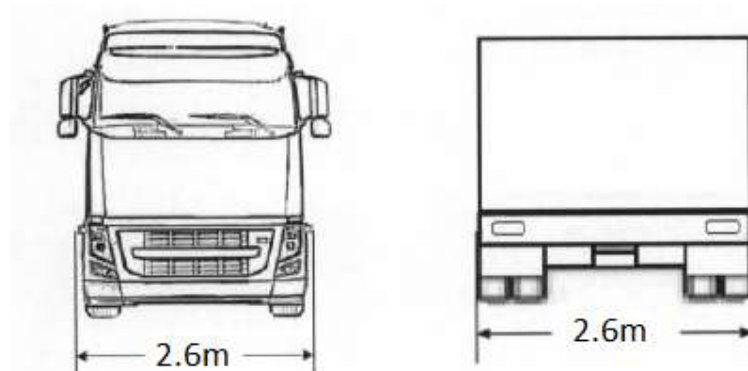

**Note:** Side cargo overhangs from the two sides of the vehicle cannot exceed 30cm.

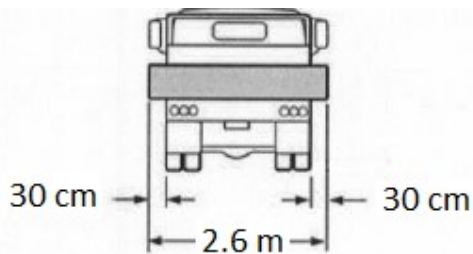

**Height:**

Maximum allowable height for all cargo vehicles with cargo and all passenger vehicles from the ground to the top of cargo or vehicle is 4.5 m along the national roads network, except for HARAZ and CHALOOS Roads.

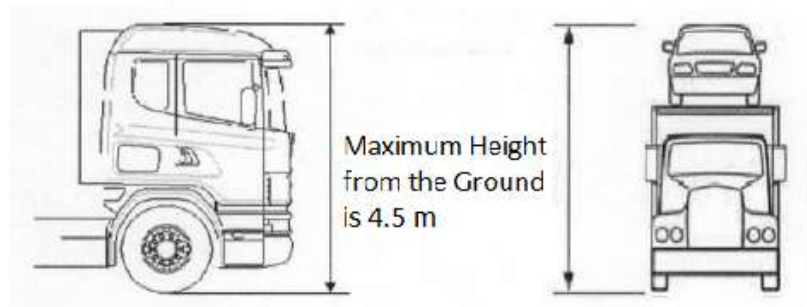

**Note:** When height limitations are put on certain roads, reducing the allowable height, the new limitations shall be publicized through The Road Maintenance and Transportation Organization.



**Article 3: Allowable weight of vehicles along the national roads network is indicated in the following table.**

**A. Axial Load**

The maximum load imposed by each axle of the vehicle (passenger or cargo) on the road surface must not exceed the limits indicated in Table 2.

**Table 2: Allowable Weight of Axle groups**

No.	Group	Axle groups			Image
		Number of Axles in Group	Number of Wheels in Group	Allowable Weight of Group (ton)	
1	Steering Axle	1	2	8	
2		2	4	14	

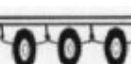
3	Single axle	1	2	10	
4			4	13	
5	Tandem axle	2	4	18	
6			6		
7			8		
8	Tri-Axle	3	6	24	
9			10		
10			12		

\* If the distance between centers of the two axles exceeds 2 meters, each axle is considered a single axle.

\*\* Tires used on single, double, and triple axles with two wheels on each axle must be radial type with minimum width of 36.5 cm; otherwise, one ton is reduced from the allowable weight of the axle group for each axle.

### B. Allowable Weight of Trucks

Allowable weight of various types of truck along the national roads network is indicated in Table 3.

**Table 3: Layout of Axle groups and Weight of Various Trucks**

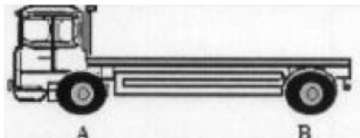
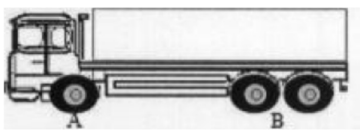
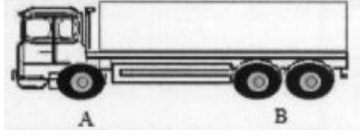
No. of Axles	Allowable Combined Weight Of Axle Groups (MT)			No. of Wheels In Axle Groups		Classification of Axle Groups	Vehicle Code
	Gross Weight (Total)	B	A	B	A		
2	19	13	8	4	2		5206
3	26	20	8	8	2		5310
3	24	16	8	6	2		5308
3	26	18	8	4	2		5306R

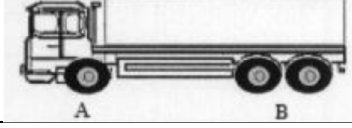
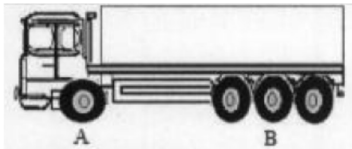
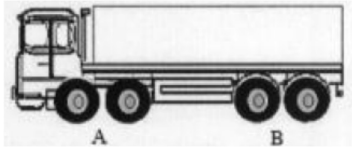
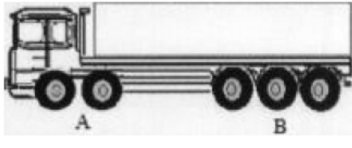
				6			5308R
4	30	24	8	10	2		5412
4	32	20	14	8	4		5412S
5	34	24	14	10	4		5514S

**Vehicle Code:** The vehicle code contains four digits; the first two digits show type of the vehicle and number of the axles, and the two last digits show total number of the wheels.

**Letters:** **R** represents radial tires with minimum width of 36.5 cm and **S** indicating for two axles in the Steering Axle group.

### C. Allowable Weight of Combination Vehicles

#### 1. Truck with Trailer (Trailer is Connected Indirectly to the Truck Using Drawbar, Lock, and Pin)

The allowable weight of various trailer trucks along the national roads network is indicated in Table 4

**Table 4: Layout of Axle Groups in Various Trailer Trucks**

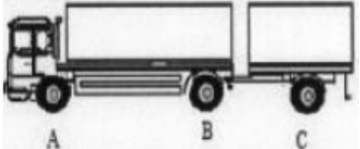
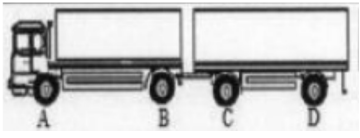
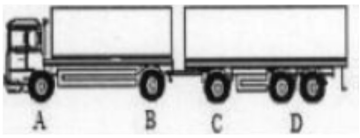
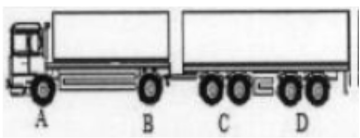
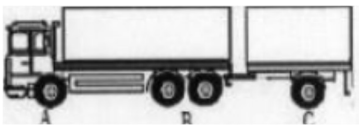
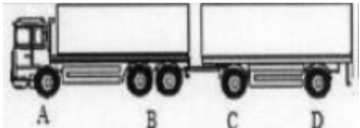
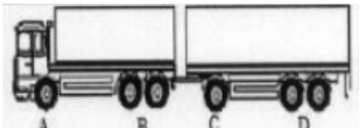

No. of Axles	Allowable Combination Weight of Axle groups (ton)							No. of Wheels in Axle groups				Classification of Axle groups	Vehicle Code
	Total Weight (Gross)	Trailer	Truck	D	C	B	A	D	C	B	A		
3	28	10	18	-	10	13	8	-	2	4	2		537108
4	30	14	16	13	10	13	8	4	2	4	2		537212
5	32	16	16	20	10	13	8	8	2	4	2		537316
6	36	20	16	20	16	13	8	8	4	4	2		537418
4	34	10	24	-	10	20	8	-	2	8	2		537112
5	38	16	22	13	10	20	8	4	2	8	2		537216
6	40	18	22	20	10	20	8	8	2	8	2		537320

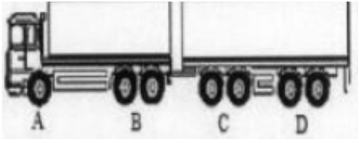

No. of Axles	Allowable Combination Weight of Axle groups (ton)							No. of Wheels in Axle groups				Classification of Axle groups	Vehicle Code
	Total Weight (Gross)	Trailer	Truck	D	C	B	A	D	C	B	A		
7	42	20	22	20	16	20	8	8	4	8	2		537422

**Vehicle Code:** The vehicle code contains six digits; the first two digits indicates type of the vehicle and number of the axels; the second two digits represents type of the trailer and number of axles; and the last two digits illustrates total number of the vehicles.

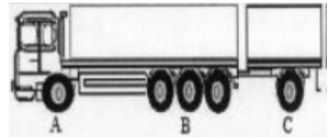
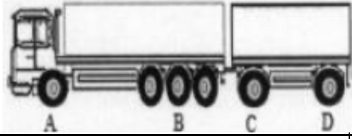
**Table 4 (Continued): Layout of Axle groups in Various Trailer Trucks**

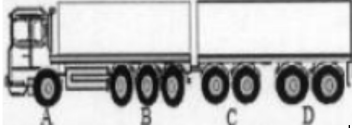
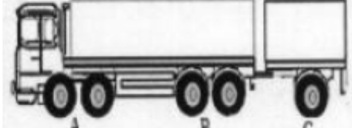
No. of Axles	Allowable Combination Weight of Axle Groups (MT)							No. of Wheels in Axle Groups				Classification of Axle Groups	Vehicle Code
	Total Weight (Gross)	Trailer	Truck	D	C	B	A	D	C	B	A		
5	38	10	28	-	10	24	8	-	2	10	2		547114
6	40	16	26	13	10	24	8	4	2	10	2		5477218
7	42	20	22	20	10	24	8	8	2	10	2		547323
8	42	22	22	20	16	24	8	8	4	10	2		547424
5	38	10	28	-	10	20	14	-	2	8	4		547114S

No. of Axles	Allowable Combination Weight of Axle Groups (MT)							No. of Wheels in Axle Groups				Classification of Axle Groups	Vehicle Code
	Total Weight (Gross)	Trailer	Truck	D	C	B	A	D	C	B	A		
6	40	16	24	13	10	20	14	4	2	8	4		547218S
7	42	20	22	20	10	20	14	8	2	8	4		547322S
8	44	22	22	20	16	20	14	8	4	8	4		547424S

**Vehicle Code:** The vehicle code contains six digits; the first two digits indicates type of the vehicle and number of the axels; the second two digits demonstrates type of the trailer and number of axles; and the last two digits illustrates total number of the vehicles.





**S:** Stands for two axles in the lead group.

## 2. Truck-Tractor Semitrailer (Semitrailer Directly Connected to the Tractor chassis by the Fifth Wheel)

Allowable weight of various types of Truck Tractor semitrailer in the the national roads network is indicated in Table 5.

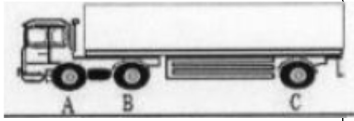
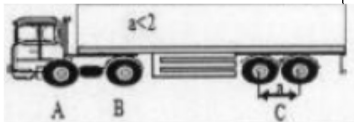
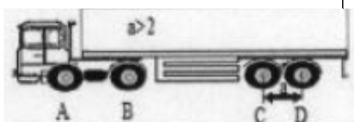
**Table 5: Layout of Axle Groups and Allowable Weight of Various Truck – Tractor semitrailer**

No. of Axles	Allowable Articulated Weight of Axle Groups (MT)							No. of Wheels in Axle Groups				Classification of Axle Groups	Vehicle Code
	Total Weight (Gross)	Semi Trailer	Tractor	D	C	B	A	D	C	B	A		
3	28	10	19	-	10	13	8	-	2	4	2		6281108R

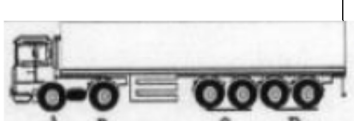
No. of Axles	Allowable Articulated Weight of Axle Groups (MT)							No. of Wheels in Axle Groups				Classification of Axle Groups	Vehicle Code
	Total Weight (Gross)	Semi Trailer	Tractor	D	C	B	A	D	C	B	A		
3	28	13	19	-	13	13	8	-	4	4	2		628110
4	32	20	19	-	20	13	8	-	8	4	2		628214
4	36	26	19	13	13	13	8	4	4	4	2		628214L
4	32	18	19	-	18	13	8	-	4	4	2		628310R
5	34	21	19	-	21	13	8	-	6	4	2		628312
5	40	24	19	-	24	13	8	-	6	4	2		628312R
5	40	24	19	-	24	13	8	-	10	4	12		628316W
		27			27				12				628318
6+	44	30	19	18	18	13	8	4	4	4	2		628414R
		36		20	20			8	8				628422

**Vehicle Code:** The vehicle code contains six digits; the first two digits indicates the type of vehicles and number of axles; the second two digits demonstrates the type of semi-trailer and number of the axles; and the last to digits illustrates total number of the wheels.

**Letters:** **R** stands for radial tire with minimum width of 36.5 cm; **L** shows that the distance between two adjacent axles of the semitrailer exceeds 2 m; and **W** shows that there is a two-wheel axle in the rear axle group.

**Table 5 (Continued): Layout of Axle groups and Allowable Weight of Various Truck – Tractor semitrailer**

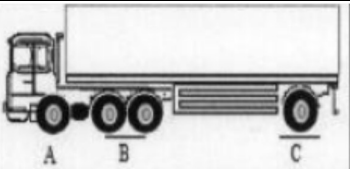
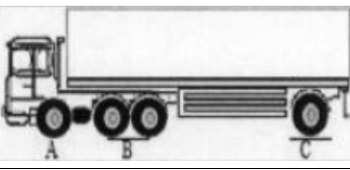
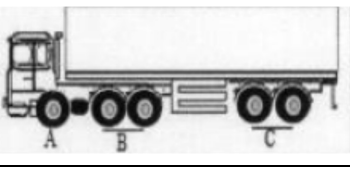
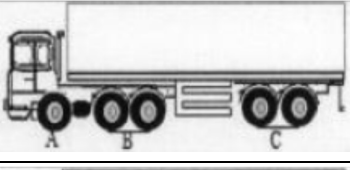
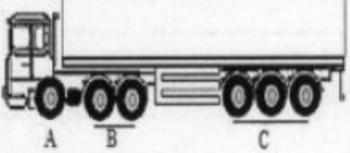
No. of Axles	Allowable Articulated Weight of Axle Groups (MT)							No. of Wheels in Axle Groups				Classification of Axle Groups	Vehicle Code
	Total Weight (Gross)	Semi Trailer	Tractor	D	C	B	A	D	C	B	A		
4	32	10	26	-	10	20	8	-	2	8	2		638112R
4	32	13	26	-	13	20	8	-	4	8	2		638114
5	40	18	26	-	18	20	8	-	4	8	2		638214R
5	40	20	26	-	20	20	8	-	8	8	2		638318
6	44	24	26	-	24	20	8	-	6	8	2		638316R

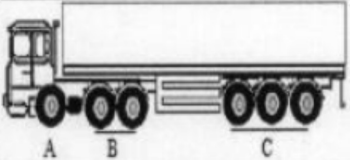
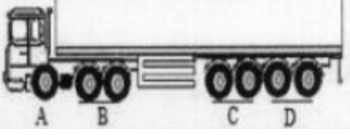
No. of Axles	Allowable Articulated Weight of Axle Groups (MT)							No. of Wheels in Axle Groups				Classification of Axle Groups	Vehicle Code
	Total Weight (Gross)	Semi Trailer	Tractor	D	C	B	A	D	C	B	A		
6	44	24	26	-	24	20	8	-	10	8	2		638320W
		27		27	12			638322					
7+	44	30	26	18	18	20	8	4	4	8	2		638418R
		36		20	20			8	8				638426

**Vehicle Code:** The vehicle code contains six digits; the first two digits indicates the type of vehicles and number of axles; the second two digits demonstrates the type of semi-trailer and number of the axles; and the last to digits illustrates total number of the wheels.

**Letters:** **R** stands for radial tire with minimum width of 36.5 cm, and **W** shows that there is a two-wheel axle in the rear axle group.

**Table 5 (Continued): Layout of Axle Groups and Allowable Weight of Various Trailer Trucks**

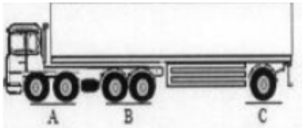
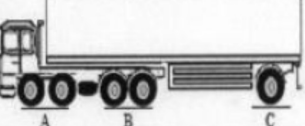
No. of Axles	Allowable Articulated Weight of Axle Groups (MT)							No. of Wheels in Axle Groups				Classification of Axle Groups	Vehicle Code
	Total Weight Gross	Semi Trailer	Tractor	D	C	B	A	D	C	B	A		
5	40	10	30	-	10	20	14	-	2	8	4		648114RS
5	40	13	30	-	13	20	14	-	4	8	4		6418116S

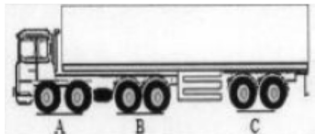
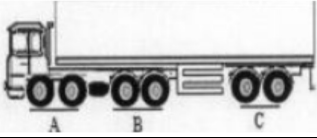
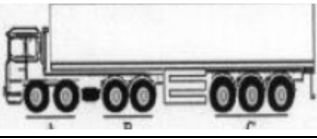
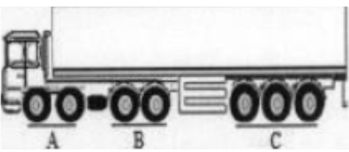
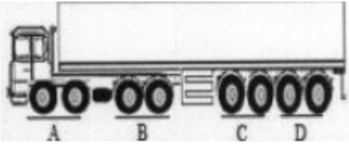
No. of Axles	Allowable Articulated Weight of Axle Groups (MT)							No. of Wheels in Axle Groups				Classification of Axle Groups	Vehicle Code
	Total Weight Gross	Semi Trailer	Tractor	D	C	B	A	D	C	B	A		
6	44	18	30	-	18	20	14	-	4	8	4		648316RS
6	44	20	30	-	20	20	14	-	8	8	4		648220S
7	44	24	30	-	24	20	14	-	6	8	4		648318RS
7	44	24	30	-	24	20	14	-	10	8	4		648322WS
		27			27				12				648324S
8+	44	20	30	18	18	20	14	4	8	8	4		648420RS
		36		20	20			4	8				648428S

**Vehicle Code:** The vehicle code contains six digits; the first two digits indicates the type of vehicles and number of axles; the second two digits demonstrates the type of semi-trailer and number of the axles; and the last two digits illustrates total number of the wheels.

**Letters:** **R** stands for radial tire with minimum width of 36.5 cm, **W** shows that there is a 2-wheel axle in the rear axle group, and **S** shows that there are 2 axles in the lead group.

**Note 1:** Rear axles of the trailer trucks with more than four axles must be steerable.

**Note 2:** Allowable weight of various types of passenger vehicles, based on their axles layout, will be the same as those indicated in Tables 3 and 4.

**Article 4:** The vehicles subject to this regulation must have tires with minimum width of 275 mm and more.

**Article 5:** Maximum weight of loaded cargo and passenger vehicles cannot exceed the weights indicated in this regulation, or in the vehicle identification card. Oversized or overweighted vehicles are not allowed to drive along the national roads network, unless the excess cargo is discharged and the vehicle size/weight complies with the regulations.

**Article 6:** When the cargo is inseparable and its size and weight exceed the size and weight indicated in this regulation, and it is obligatory to transport them along the road, the cargo must be transported under the conditions specified in the oversized cargo manual, with the permission of Road Maintenance and Transportation Organization or other authorized centers.

**Article 7:** In case of violating this regulation, the offending vehicle is introduced by the Traffic Police to the Road Maintenance and Transportation Organization to pay the damages made on the road in accordance with the Article 31 of the *“Law on Driving Infringement”* and compliance with the regulation. The vehicle return to the road is subject to its status complying with this regulation, and the damages disbursement by the transport company or the driver.